

Pass-through warewasher  
ValueLine P50

**winterhalter**

## High Performance to the Core



## Excellent results in the shortest time

The ValueLine P50 delivers excellent cleaning results quickly and effectively. It is easy to operate and users can trust in its level of efficiency, hygiene and reliability. This makes the P50 extremely attractive for professionals in search of an economical and practical solution for their growing warewashing needs.



### Easy to operate

- Clear colour-coded digital display
- 2 wash programmes
- Digital tank and boiler temperature display
- Error management system with pictograms and error logbook
- Thermostop controlled rinse temperature
- Automatic hood start
- Self-cleaning programme



### Excellent results and hygienic design

- Rotating top and bottom wash system for optimum coverage
- Triple filtration system ensures extended lifecycle of tank water
- Wash and rinse arms easily removable by hand for cleaning
- Deep drawn tank for optimal hygiene
- Hygiene rack guide



### Economical to run

- Short wash cycle
- Reduced heating time
- Low total connected load at 3-ph 20 Amp
- Low fresh water consumption
- Optional integrated waste water heat exchanger with additional 1.7kW heating power helps to save energy costs

## Technical Data

P50		
Number of programmes		2
Theoretical capacity (Standard/ High Temp)	[racks/h]	60/20
Rack dimensions	[mm]	500 x 500
Tank capacity	[l]	28
Tank temperature	[°C]	62
Tank heating	[kW]	2.5
Boiler heating	[kW]	9.0
Rinse water consumption	[l/rack]	2.4
Final rinse temperature	[°C]	85
Circulating pump		
– Volume circulated	[l/min]	210
– Output (p1)	[kW]	0.6
Noise emission	[dB(A)]	max. 63
Splash guard		IP X3
Minimum flow pressure	[kPa/bar]	100/1.0
Maximum inlet pressure	[kPa/bar]	600/6.0
Rate of flow	[l/min]	min. 4
Water inlet temperature	[°C]	max. 60
Weight (net/gross)	[kg]	98/123
Packaging dimensions (W x D x H)	[mm]	770 x 880 x 1605

## Electrical specifications

Supply	Fuse	Total connected load
400 V/3N~/50–60 Hz	16 A	9.3 kW
	20 A	11.8 kW
230 V/3N~/50–60 Hz	25 A	9.3 kW
	32 A	11.8 kW

## Dimensions

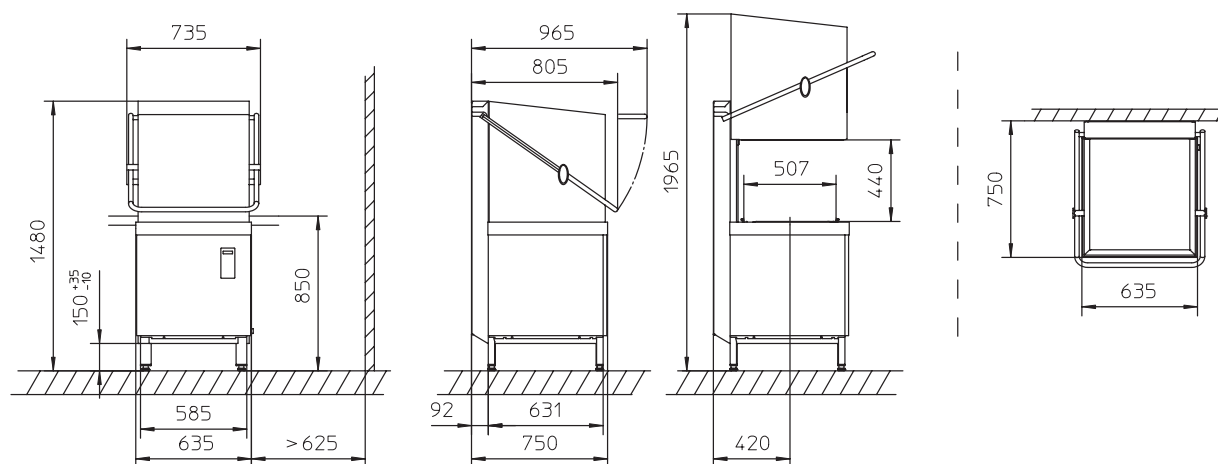

**SEA Regional Office:**

**Winterhalter (M) Sdn. Bhd.**

12, Jalan PJU 3/46,  
Sunway Damansara Technology Park,  
47810 Petaling Jaya Selangor, Malaysia  
Tel.: +6 03 7803 6621; Fax: +6 03 7803 1129  
[www.winterhalter.com.my](http://www.winterhalter.com.my)

**PT. Winterhalter Indonesia PMA**

Rukan Inkopal Blok G46-47,  
Jl. Boulevard Barat Raya - Kelapa Gading,  
Jakarta Utara 14240, Indonesia.  
Tel.: +62 21 4585 1556; Fax: +62 21 4585 1554  
[www.winterhalter.co.id](http://www.winterhalter.co.id)

**Winterhalter Singapore Pte Ltd**

Blk 186, Woodlands Industrial Park E5  
#03-01E Singapore 757515  
Tel.: +65 6368 5808; Fax: +65 6368 1880  
[www.winterhalter.sg](http://www.winterhalter.sg)

**Winterhalter Gastronom Vietnam Co., Ltd.**

660 Dien Bien Phu Street,  
Ward 11, District 10, HCMC, Vietnam.  
Tel.: +848 3830 1795; Fax: +848 3830 1796  
[www.winterhalter.vn](http://www.winterhalter.vn)

**Winterhalter (Thailand) Co, Ltd.**

174 Lad Phrao 64,  
Lad Phrao Road, Wong Thong Lang,  
Bangkok 10310, Thailand.  
Tel.: +66 2 539 3279; Fax: +66 2 539 3280  
[www.winterhalter.co.th](http://www.winterhalter.co.th)