

1000-MR2

MOBILE REFRIGERATED CART



• The Alto-Shaam Mobile refrigerated Cart is not just a refrigerator on wheels, but a well-designed and efficient system for storing and transferring refrigerated food products.

- Adjustable shelves allow for the storage of plated items, pans or other items.
- Full perimeter stainless steel bumper, transport handles, heavy duty casters along with the cart's reduced height provide easy mobility.
- Electronic thermostat has digital display to view inside set air temperature.
- Non-magnetic stainless steel surface resists corrosion.
- Environmentally safe refrigerant.
- All mechanical equipment is easily accessible, without the use of tools, for ease in servicing.
- Center mounted cooling coil balances and distributes air evenly.
- Condensate from the cooling coil is used to cool the compressor, therefore, it is unnecessary to have an alternate means of water disposal.

Double cavity model with 20 gauge, non-magnetic stainless steel exterior and door, fully insulated with high density foamed-in-place polyurethane. Doors include two (2) positive door latches with magnetic-mechanical closing and cylinder door lock. 22 gauge non-magnetic (non-corrosive) stainless steel interior includes four (4) removable stainless steel side racks with 50 shelf positions spaced on 1-1/4" (32mm) centers, six (6) powder coated shelves, 26-1/2" x 21-3/4" (673mm x 552mm).

The mobile refrigerator is controlled by one (1) ON/OFF switch, with a factory set temperature of 36°F (2°C). A LED display monitors the inside temperature. Unit includes one (1) transport handle on each end of the cart, and a full-perimeter stainless steel bumper guard. Cart is furnished with removable side racks, six (6) powder coated shelves, six (6) 5" (127mm) heavy duty casters — two (2) rigid and four (4) swivel with brake and rear power cord storage during transport. One (1) 1/3 horsepower compressor system utilizes 134a refrigerant, generating 2560 BTU per hour.

MODEL 1000-MR2: Double compartment Mobile Refrigerated Cart

FACTORY INSTALLED OPTIONS

- Temperature display in Fahrenheit is standard.
 - Specify degrees Celsius on order as required.
- Specify voltage requirement on order as required.
 - 115V
 - 220V

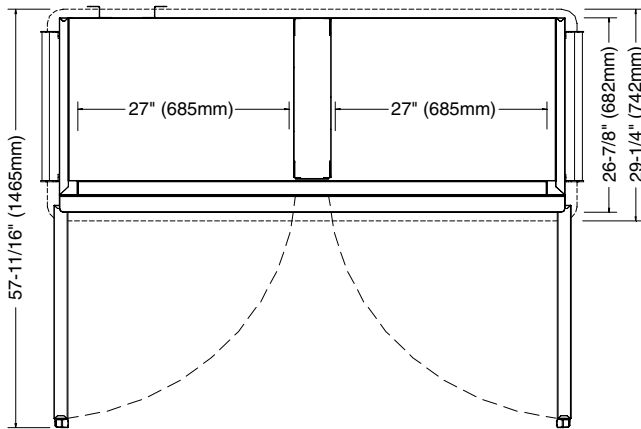

DIMENSIONS: H x W x D
EXTERIOR: 68-1/2" x 67-1/2" x 29-1/4" (1740mm x 1715mm x 742mm)
INTERIOR PER COMPARTMENT: 21-1/4" x 27-1/4" x 55-1/2" (540mm x 692mm x 1410mm)

ELECTRICAL					
VOLTAGE	PHASE	CYCLE/HZ	AMPS	kW	CORD & PLUG
220-240	1	50	5.5	0.651	 TIS 166-2549

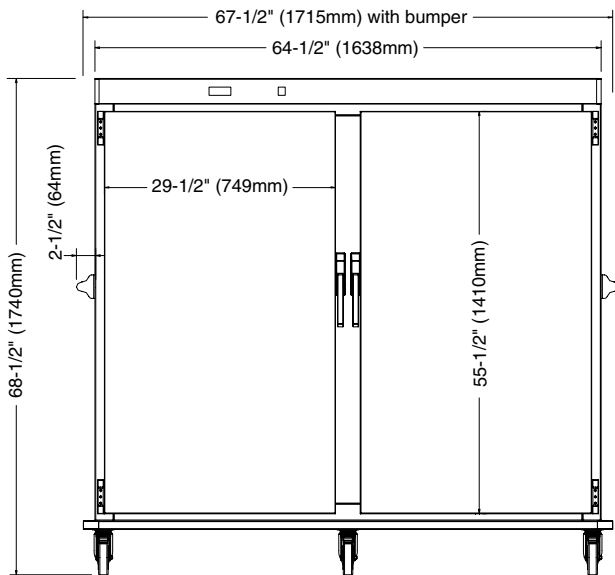

PRODUCT/PAN CAPACITY
504 lb (229 kg) MAXIMUM VOLUME MAXIMUM: 315 QUARTS (399 LITERS)
FULL-SIZE PANS: GASTRONORM 1/1: Fourty-two (42) 20" x 12" x 2-1/2" (530mm x 325mm x 65mm)
FULL-SIZE SHEET PANS: Twenty-six (26)* 18" x 26" x 1" ON WIRE SHELVES ONLY *ADDITIONAL SHELVES REQUIRED

INSTALLATION REQUIREMENTS
<ul style="list-style-type: none"> — Cart must be installed level. — Cart must not be installed in any area where it may be affected by steam, grease, dripping water, extreme temperatures, or any other severely adverse conditions.

CLEARANCE REQUIREMENTS
Full perimeter bumper accommodates all clearance requirements.

WEIGHT	
NET: 557 ± 22 lb (253 ± 10 kg)	SHIP: 693 ± 22 lb (315 ± 10 kg)
CARTON DIMENSIONS: (L x W x H)	
31-15/16" x 42-3/4" x 70-7/8" (810mm x 1085mm x 1800mm)	

OPTIONS & ACCESSORIES	
Plate Carriers, CONTACT FACTORY FOR CAPACITY	
<input type="checkbox"/> Covered "C" Carriers	DC-2869
<input type="checkbox"/> Covered "EC" Carriers	DC-23676
<input type="checkbox"/> Uncovered "P" Carriers	DC-2868
<input type="checkbox"/> Uncovered "EP" Carriers	DC-23580
Shelves, 26-7/8" x 19-5/8" (683mm x 498mm)	
<input type="checkbox"/> Powder Coated	SH-35956