

FRYMATIC

Continuous Fryer



LARGE-SCALE FRYING MADE EASY

Frying large quantities of foods has always been problematic: as well as the many production difficulties, wastage levels are high, labour efficiency is low, and quality results are poor. The **Frymatic** continuous fryer is the solution to these problems.

It fries breaded meat, crisps, chips, fish, aubergines, chicken breasts and drumsticks, tourtons, nems, acras, confectionery and all products that have to be fried to a perfect golden finish, at impressively low costs.

Thanks to its original construction and innovative features, **Frymatic** delivers absolutely exclusive benefits:

- high productivity in a compact size
- minimal labour requirements
- long frying oil lifetime
- high quality, easily digested end product
- very easy to clean

as well as the other features typical of all **Nilma** appliances: low energy costs, rugged construction in 18/10 stainless steel throughout, perfect compliance with standards and absolute reliability and operating safety. All these qualities make **Frymatic** the perfect solution to the quality and economic needs of large kitchens and food producers.

Nilma

LA SCIENZA DELLE GRANDI CUCINE



FRYMATIC

Continuous Fryer



No more dirty oil

The Frymatic's built-in recycling pump with filter automatically filters the used oil from the recycling tank and returns it, clean, to the frying tank.



The right Frymatic for every user

The technical specifications of each Frymatic can be tailored to the output rate required and the type of food to be fried. Fryers are produced with a belt width of up to 800 mm.



FEATURES	CONSTRUCTION FEATURES
	<ul style="list-style-type: none">• Constructed in 18/10 stainless steel throughout• Product conveyor and immersion belts in 18/10 stainless steel mesh• Belt speed adjustable to suit the type of product for frying• "Cold zone" frying tank• Product loading hopper removable for cleaning• Oil recycling tank in 18/10 stainless steel, with recycling pump and filter• Standard belt width: 450 mm• Standard product passage height between belts: 60 mm
FEATURES	FUNCTIONAL FEATURES
	<ul style="list-style-type: none">• Low voltage control panel with master switch, belt speed regulator, temperature pilot lights, digital thermoregulators for oil temperature, belt tipping button, oil pump switch, and burner reset button (gas version)• Automatic belt lifting for cleaning of the frying tank• Electronic frying oil anti-cracking device (for electric versions from 48 to 144 kW only)• Dual device for independent oil temperature regulation (for 60 kW gas version and electric versions from 48 to 144 kW only)• Frying time and temperature adjustable to suit the food for frying• Safety thermostats• Lid with frying vapours outlet (for 60 kW gas version and electric versions from 48 to 144 kW only)• Electronic digital thermometer for visual checking of load position and oil temperature

Easy to programme

Frymatic is easy to programme thanks to a very user-friendly control panel. Just set the ideal frying temperature on the thermostats and select the best belt speed for the product and healthy, tasty frying is assured.

Unbeatable hygiene

A continuous fryer has to save production time. But this saving can be cancelled out by complex cleaning procedures. To prevent this, **Frymatic** has a frying tank with rounded corners, an easily removable loading hopper, and belts that can be lifted automatically for full access to the frying tank.



Everything under control

On request, **Frymatic** can be fitted for connection to the Nilma "Creative Control Machine

Point" software, able to provide HACCP temperature/time logging and select operating modes to suit the product for frying. CCMP also carries out autodiagnosis on operation of the appliance, recording any technical anomalies. The operating data is stored in special files on a PC.

ACCESSORIES

Fried food collection trolley

in 18/10 stainless steel, with three GN 2/1 containers, h 150 mm
Dimensions:
590x660x810 mm



Wheeled food loading belt

in 18/10 stainless steel with control panel with start/stop button and speed setting control
Dimensions:
1500x650x1050h
Belt width: 400 mm
Electricity supply connection: 0,07 kW- 230V50Hz 1ph+T



TECHNICAL DRAWINGS

FRYMATIC

gas
30 kw

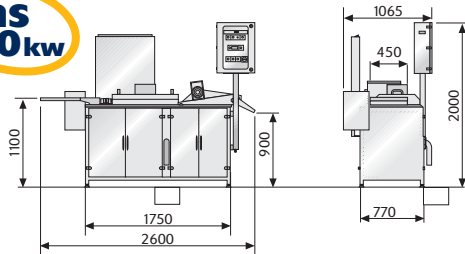

FRYMATIC

gas
60 kw

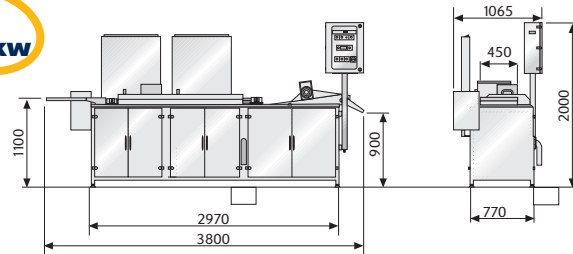

FRYMATIC

elect.
24/34 kw

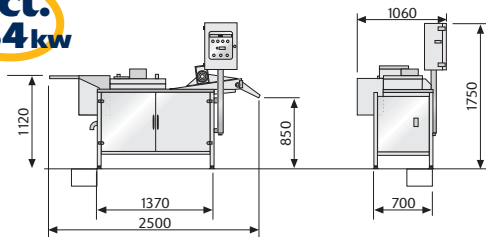

FRYMATIC

elect.
48/72 kw

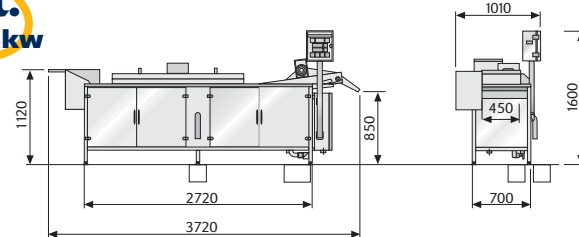

FRYMATIC

elect.
120/144 kw

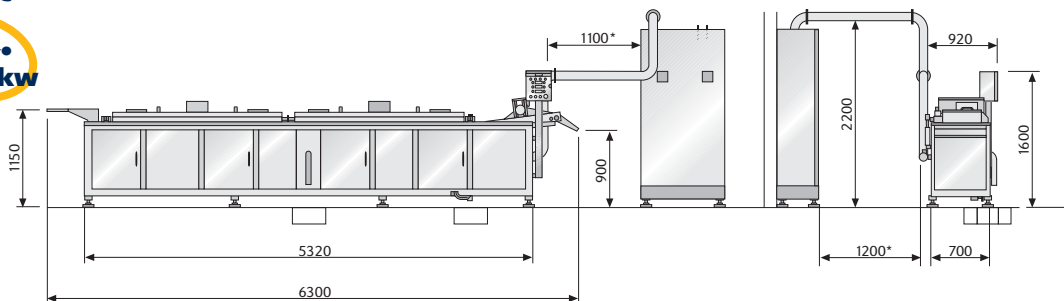

* Minimum value, may vary depending on requirements

TECHNICAL DATA

	GAS		ELECTRIC					
	30 Gas	60 Gas	24 Elect.	34 Elect.	48 Elect.	72 Elect.	120 Elect.	144 Elect.
Electrical connection	230/400V 50Hz 3ph +N +T		230/400V 50Hz 3ph +T					
Heating power kW	30	60	24	34	48	72	120	144
Electrical power kW	1,5	1,5	25	35	49	73	121	145
Gas supply connection Ø	1/2"	1"	-	-	-	-	-	-
Frying tank capacity L	160	290	100	100	230	230	430	430
Hourly production rate kg/h*	40	80	40	60	80	120	200	240

* Production rates may vary considerably depending on the temperature, piece size or type of the food for frying. Production data refers to the product entering the fryer.

VERSIONS

Gas: with burners with electronic ignition and safety sensor.

Electric: with incoloy steel heating elements.



APPLIANCE CONSTRUCTED TO HARMONISED STANDARDS AND COMPLETE WITH CE MARKING

Nilma holds ISO 9001 and VISION 2000 certification