

GAS SKILLET WITH MANUAL TILT



Model	Btu	Capacity	
GTS-30	80,000	30 gallon	114 litre
GTS-40	100,000	40 gallon	152 litre

OPERATION SHALL BE BY:

Electric heating elements equipped for operation on:
 115 VAC, 1 Phase , 50/60 Hz, 2 Amps.

STANDARD FEATURES

- ✓ Permanently lubricated tilt mechanism
- ✓ Stainless steel cover with spring assist hinges, full width handle, no-drip condensate guide and vent port with swing cover.
- ✓ 5/8" clad plate cooking surface with 10 gauge sides.
- ✓ All stainless steel exterior.
- ✓ Pour lip strainer.
- ✓ Solid state temperature control.
- ✓ Solid state multi-trial DSI type ignition.

OPTIONAL ITEMS AT EXTRA COST:

- 220 VAC, 1 Phase , 50/60 Hz
- Vented pan cover.
- Etched gallon markings (GMS-30, GMS-40).
- Etched litre markings (LMS-30, LMS-40).
- 2" draw off valve with strainer, side mounted (TVT-2BP).
- 3" draw off valve with strainer, side mounted (TVT-3BP).
- Correctional package

ACCESSORIES:

- Pan carrier (PC-1).
- Steam pan insert (SPI-30, SPI-40).
- 12" Single pantry faucet with swing spout (SF-12).
- 12" Double pantry faucet with swing spout (DF-12).
- 3" Stainless steel faucet plumbing enclosure.(3139-1)
- Single pantry faucet and bracket with 60" pot filler (SF-60).
- Double pantry faucet and bracket with 60" pot filler (DF-60).

SPECIFICATIONS:

Shall be a CROWN Model _____, gas fired skillet with manual tilt, AGA/CGA and NSF Certified. The unit shall have a stainless steel cover with spring assist hinges, full width handle, no-drip condensate guide and vent port with swing cover. The pan shall have a sloped front and front hinged for easy tilting pour control and comes complete with a removable pour strainer. Pan is formed from 10 gauge stainless steel with a #4 finish exterior and polished interior with covered corners for ease of cleaning. Cooking surface shall be 5/8" thick stainless steel clad plate ensuring even heat distribution over entire cooking surface.

Controls shall be housed in a drip proof stainless steel console and supported on 1-5/8" (41 mm) diameter stainless steel all welded tubular frame with adjustable feet on the front and flanged adjustable feet on the rear for securing to the floor. Controls include solid state thermostat, temperature light, pan tilt interlock switch, ignition light, high limit thermostat and electronic ignition are all enclosed in the left hand console. The right hand console houses the tilting mechanism which shall allow the pan to tilt forward a full 90° for complete emptying and shall be self locking for positive stop action.

The skillet shall operate on a temperature range of 100°F to 450°F (38°C to 232°C) and high temperature cut-off set at 536°F(280°C).



CROWN DETAILS AND DIMENSIONS

SERVICE CONNECTIONS

- Ⓐ – Supply gas through 1/2" pipe . A gas shut-off valve must be installed in supply piping convenient and adjacent to appliance.
- Ⓔ – Electrical Connection, unless otherwise specified 120 Volts, 60 Hz, 1 PH. furnished with 3 prong plug and cord. Less than 2 amperes.
- Ⓒ – COLD WATER: 3/8" O.D. tubing to faucet (OPTIONAL)
- Ⓓ – HOT WATER: 3/8" O.D. tubing to faucet (OPTIONAL)

DIMENSIONS

MODEL	CAPACITY	UNITS	A	B	C	D	E	F	G	H
GTS-30	30 gallons	inches	49.5	37.25	33.5	23.50	43.13	37.25	10.5	74.25
	114 litres	mm	1257	959	851	597	1095	946	267	1886
GTS-40	40 gallons	inches	58.5	38.88	43.5	23.0	51.75	37.25	10.5	74.25
	152 litres	mm	1486	988	1105	584	1314	946	267	1886

MODEL	SHIPPING WT.	GAS SUPPLY		MIN. CLEARANCE *			
		BTU/HR.	kW/HR.			SUPPLY PIPE PRESSURE (W.C.)	
GTS-30	684 lbs. [310 kg]	80,000	23.4	Natural 7"–14" (178–356mm)	Propane 11"–14" (279–356mm)	SIDES	0
GTS-40	725 lbs. [328 kg]	100,000	29.3			BACK	6 [152]

* Use on non-combustible floors only.

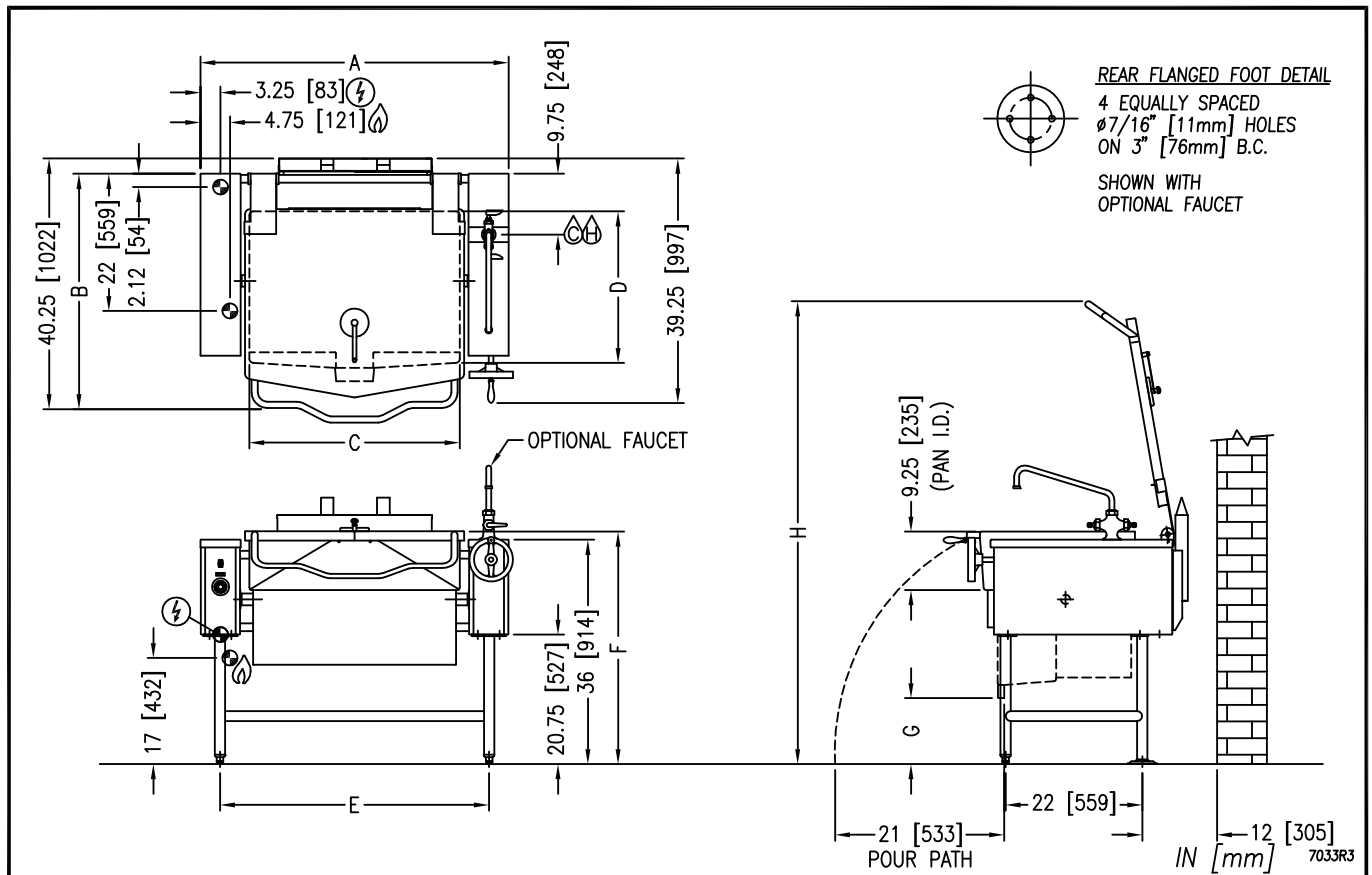

As continued product improvement is a policy of Crown, specifications are subject to change without notice.